

Insight cable connections for Site Verification

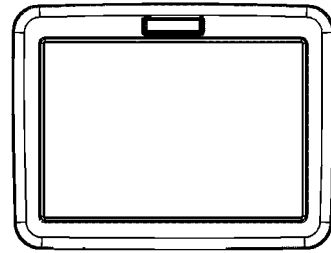

Site Verification Cable Part Numbers

4000319-1 - Power and GPS Cable

(Choose one of the following power cables)

2000452-4 – Battery Power Cable (15ft)

-or-

4000320-6 - Cigarette Lighter Pwr Cable (6ft)

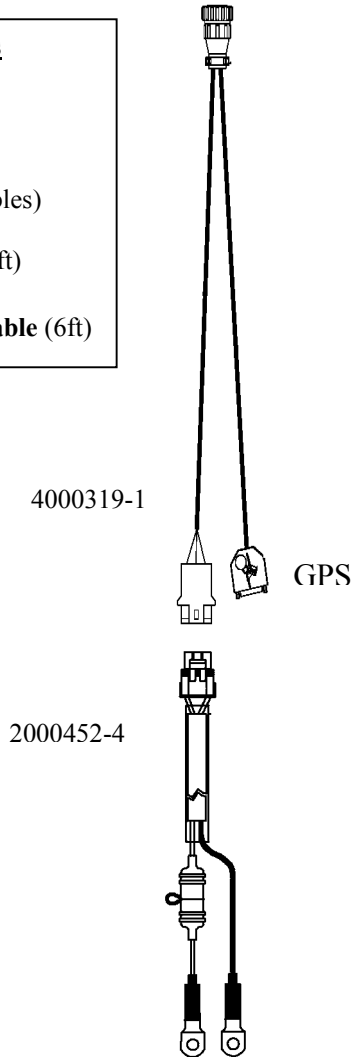

Insight cable connections for Implement Switch

Implement Switch Cable Part Numbers

4100500 – Tractor Kit (A thru E)

A-4000306-10 - Display Cable (10ft)

B-4000307-1 - Distribution Cable

C-4000379 - Pwr Control Relay

D-4000318-3 - CAN stub (3 ft)

E-4000160 - CAN App Rate Module

4000310-1 - I/O Distribution Cable

2000453-x – Impl./Flow Ext. Cable

(2= 10ft. or 3= 25ft.)

4000335 - Implement Switch

2000452-4 – Battery Power Cable (15ft)

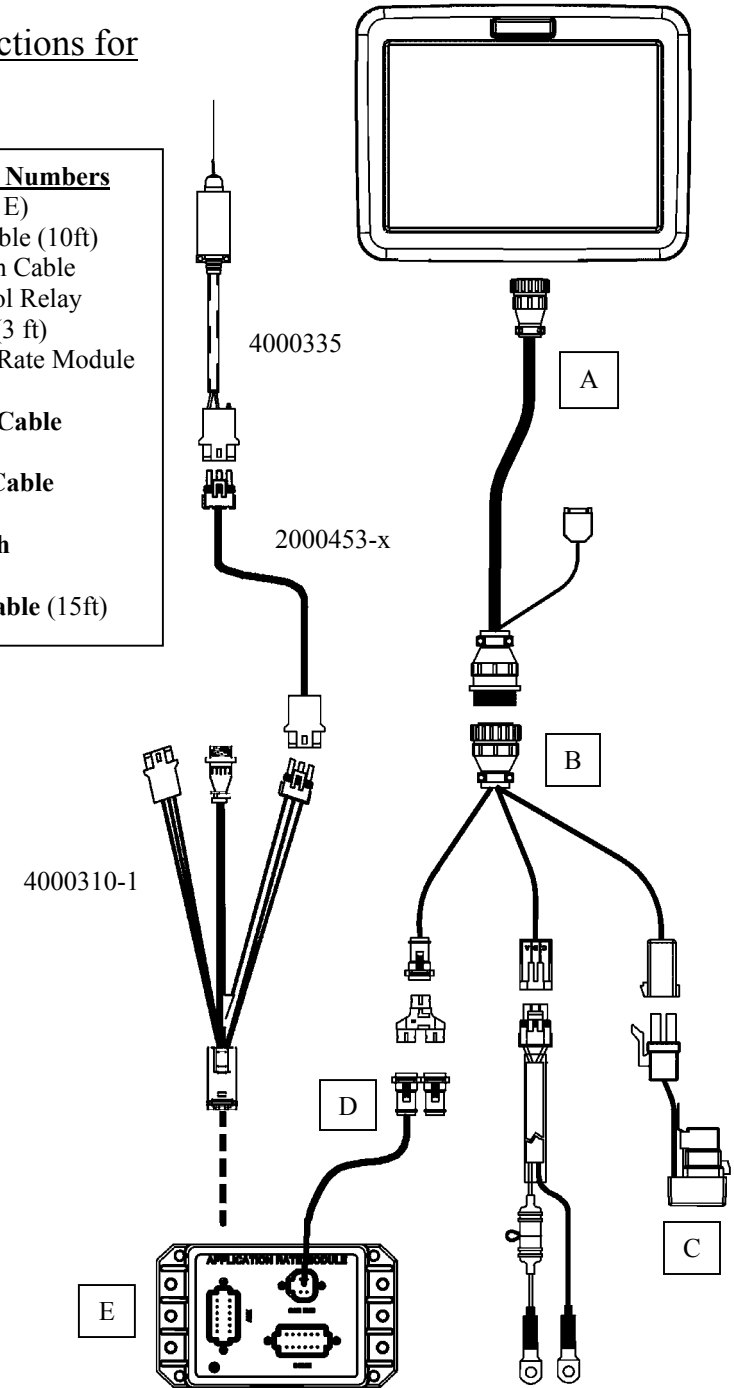

First Time Startup (Grower / Field Management)

Note: You must perform the initial Grower/Field Management section before you can perform any operation on the Insight display.

Power on the Insight by pushing the WHITE POWER BUTTON , which can be found on the back lower left hand corner of the display	
	Press the SETUP button to begin your initial setup (located on the right hand side of the display.)
1	Press the GROWER/FIELD MANAGEMENT button.
2	To add a new Grower to the system, press the ADD button under the Grower tab.
3	Press the NEW button to begin adding grower information
	3a Press the KEYBOARD button to enter a Business name. (If you are using desktop software it is recommended to use the same names as in the software.)
	3b Once you have entered the Business name push the ACCEPT button to return to the Business/Person Setup screen. Press the NEXT button.
	3c Type the first and last name of the contact person for the Business using the keyboard on the display.
	3d Press the FINISH button when finished entering information for the current grower.
3e If you wish to add additional growers, return to step 3 above. If you are done entering growers, press the ACCEPT button.	
4	Select the SEASON tab.
	4a Press the NEW SEASON button.
	4b Use the name provided or enter a name of your choice.
4c Press the ACCEPT button when finished.	
5	Select the FIELD tab.
	5a Verify that the current grower is displayed in the Grower Window. If the current grower is not displayed, choose the correct one from the list.
	5b To enter farms and fields, press the ADD button. Select a farm from the list, or press the NEW button to enter a new farm name. Press NEXT to proceed.
	5c Press the NEW button to add fields to the farm. Use the keyboard to type the field name and then press ACCEPT . Repeat this step until all fields are entered for the farm.
5d Press the FINISH button when finished. If you have additional fields, it is recommended to enter them all at this time.	
6	Once finished with Grower/Field Management setup you may press the SETUP button to return to the setup screen or the Run button to proceed to the main operating screen.

Site Verification Setup

Note: The setup wizard built into the Insight will walk you through the steps listed below.

SITE VERIFICATION CONFIGURATION	
	Press the SETUP button to begin your initial setup (located on the right hand side of the display.)
Press the SITE VERIFICATION button to enter the configuration screen.	
Press the ADD button to start the setup wizard to create a new configuration.	
Step 1	Select the Operation Type from the list and press the Next button.
Step 2	Vehicle Setup - Select the desired vehicle from the list then press Next and proceed to step 3. If your vehicle is not listed press the NEW button and proceed to 2a.
	Step 2a Select correct Vehicle Type from the list and press the NEXT button.
	Step 2b Press the KEYBOARD symbol to label the vehicle Make and Model (These settings are OPTIONAL). Once finished press the ACCEPT button.
	Step 2c Once Vehicle is defined press the Next button.
	Step 2d If using a Self-Propelled Spreader or Sprayer, you will be prompted to enter a full swath width, number of boom sections and boom widths. (This step is skipped if using a Tractor, ATV, or Pickup Truck)
	Step 2e The Vehicle name will default to the Make and Model you entered in step 2. If you would like to edit the name press the KEY BOARD button and type your preferred name. Press the ACCEPT button when finished.
Step 2f	Press the FINISH button to save your vehicle and proceed to Step 3.
Step 3	Select the desired implement from the list then press Next and proceed to step 4. If your vehicle is not listed press the NEW button and proceed to 3a. Note: This step is skipped with Self-Propelled Spreaders or Sprayers
	Step 3a Select correct Implement Attachment Method and press the NEXT button.
	Step 3b Enter appropriate swath width, number of boom sections, boom widths and distance from hitch to application point. When finished, press the NEXT button to proceed
Step 3c	Press the KEYBOARD button to enter an implement name and press the ACCEPT button when complete. Press the FINISH button to save and proceed to Step 4.

SITE VERIFICATION CONFIGURATION (cont.)	
Step 4	If using an Implement Switch, choose whether it is standard or reversed from the list. If not using an Implement Switch set to none. Press NEXT to proceed to step 5.
Step 5	Select the desired Ground Speed Source. In most cases GPS will be the primary speed source with Wheel or Radar as the backup. If you are using a backup ground speed source it is recommended that you calibrate it before the season begins. Press NEXT . (Ground Speed calibrations are completed under the CALIBRATE DISTANCE button on the Application Rate Configuration Screen.)
Step 6	The Configuration name will default to a name based on your previous configuration settings. If you would like to edit the name press the KEYBOARD button and type the preferred name. Press the ACCEPT button when finished. Press the FINISH button to save your Configuration.

Configuration Settings	
Step 7	Additional settings may be necessary for proper operation. Highlight the desired configuration from the Configuration Window and press the CONFIGURATION SETTINGS button to adjust these settings. Press the ACCEPT button when finished

PRODUCT SETUP		
Select the PRODUCT tab in the Site Verification menu to setup your products.		
Step	Press the ADD button to begin the Product Setup Wizard.	
Step 8a	Select the appropriate Product Type from the list and press NEXT and proceed to 7b. If <i>Fertilizer</i> is selected, proceed to 7d.	
Step 8b	If <i>Planted Seed</i> was selected you will be asked to identify which crop it belongs to, and also if the product is measured in seeds or pounds. If any other product type is selected you will be asked to set the units which will be logged. Press the NEXT button when finished.	
Step 8c	Press the KEYBOARD button to label the product's manufacturer (optional) and name (required). Press the FINISH button to save your Product.	
Step 8d	If <i>Fertilizer</i> was selected you will then need to choose the fertilizer that you will be applying. If the fertilizer that you are applying is not in the list choose <i>User Defined</i> . Press NEXT when finished.	
Step 8e	Press the KEYBOARD button to label the fertilizer's manufacturer (optional). Press the FINISH button to save your product.	
Operation		
Step 1		Press the RUN button to enter your main operating screen (located on the lower right hand side of the display.)
Step 2	Press the FIELD button to select which field you will be logging to.	
Step 2a	Select the appropriate Grower, Field, Operating Configuration, and Product from the lists. If your item is not listed, refer to the appropriate section in this guide to set it up. If you applying the same product multiple times during a single season, you can create a new Operational Instance by pressing the Change button next to Operational Instance. Press the ACCEPT button when finished.	
Step 2b	If data has not been logged to the current field, a window to select the Region will appear. The name may be edited by selecting the EDIT NAME button or you may press ACCEPT to use the default.	

AREA COUNTING (Run Screen)
The area switch is located in the lower right hand corner of the display. The button should read AUTO to count area. If you do not want to count area, you may press the area switch button, which will switch it to OFF.