

# **GPS 1000**

## **INSTALLATION AND GENERAL INSTRUCTIONS**



**Important Notices**

Before beginning installation of your GPS 1000, please take the time to thoroughly read these instructions. Signal words (**CAUTION**, **IMPORTANT**, and *NOTE*) are provided to draw attention to information that is important for the safe/correct installation and operation of this product.

- **CAUTION**--will alert you to situations that will impact the physical safety of you or others.
- **IMPORTANT**—will alert you to the potential for damage to the product or loss of data.
- *NOTE*--will provide you with additional information to simplify a procedure or clarify a process.

After completing installation of the GPS 1000 we recommend that you place these instructions in the Options Section of your YM 2000, PF3000 or PF3000 Pro Operator's Manual to prevent their loss.

*To receive upgrade/update information of this product you must send in or fax the Registration Form. Refer to the Registration Form for address and fax number.*

<b>Item</b>	<b>Page</b>
General Instructions	2
Product Overview	2
General Information	2
Using GPS 1000 Utility Version 1.0	5
Installing Antenna/Receiver	6
Parts, Tools for Antenna Installation	6
Installing the Antenna on Combine or Tractor	6
Routing the Cable to Cab	7
Other Cable Connections	9
Specifications	11
Troubleshooting	13
Parts List	14
GPS 1000 Owners Registration	

---

**Product Overview**

The GPS 1000 is an all in the antenna DGPS receiver that provides position data for operations that do not require sub-meter position accuracy or guidance. The GPS 1000 utilizes differential correction from the WAAS satellite differential system. The GPS 1000 provides 2-meter accuracy when using WAAS differential and 4 meter accuracy without any differential correction.

The GPS 1000 is a valuable addition for general data logging such as soil sample collection, scouting, site verification or as a second GPS receiver for yield mapping.

The GPS 1000 is weatherproof and protected against power surges that are common on agricultural equipment. The GPS 1000 is also backed by a 2-year warranty.

---

**General Information**

Wide Area Augmentation System (WAAS) differential correction is an alternative to subscription based satellite differential correction.

**IMPORTANT: WAAS is currently free of charge, and is being funded by the Federal Aviation Administration (FAA). WAAS is currently in test mode, and Ag Leader Technology can not guarantee the availability or quality of its position signals. Only two (2) WAAS satellites are currently covering North America.**

The GPS 1000 requires no initial setup to begin fieldwork. The PF3000, (Figure 3) or YM 2000, (Figure 4) will display a "D" or "G" on the top right hand corner of the display to indicate a GPS signal. A "D" indicates that a differential signal is being received. A "G" indicates that you have a GPS signal and your GPS receiver is tracking four or more satellites (which means you can get an elevation reading). A lower case "g" indicates that you have a GPS signal but your GPS receiver is tracking only three satellites which means you can not get an elevation reading. Your GPS receiver must track four or more satellites to get an elevation reading.

The unit is defaulted to 4800-baud, 8, N, 1 output. One position is output per second using GGA and VTG NMEA messages by default.

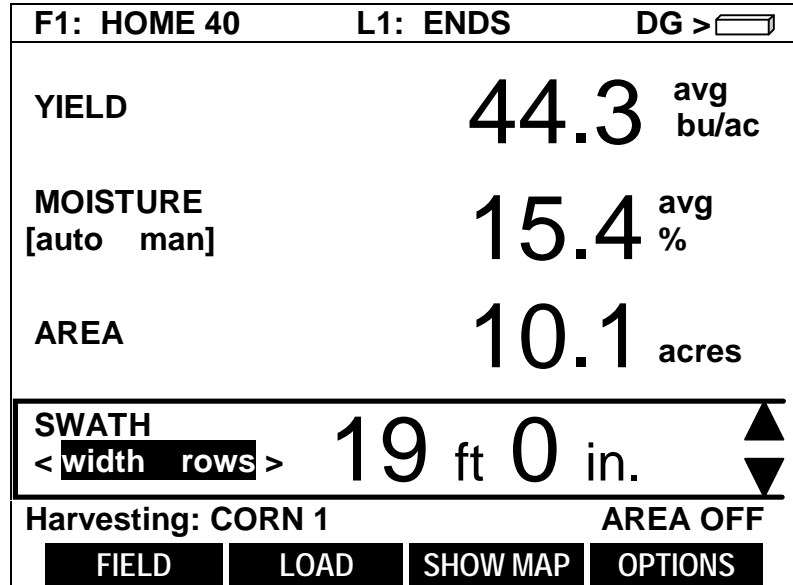

Figure 1. PF3000 screen with DG displayed



Figure 2. YM 2000 screen with DG displayed

To view NMEA messages on the PF3000:

Press MENU key until DIAG is displayed and press the DIAG key.

On the DIAGNOSTIC SELECTIONS screen press the RAW NMEA key to view the GGA and VTG strings. See Figure 8.

```
NMEA DIAGNOSTICS  
  
Valid GGA and VTG strings...  
$GPGGA,182118.00,4201.1377,N,09338.1416,W,2,0  
8,0.9,276.05,M,-31.54,M,5.4,0166*7F  
$GPVTG,168.7,T,,000.13,N,000.25,K*20  
$GPGGA,182119.00,4201.1377,N,09338.1414,W,2,0  
8,0.9,275.97,M,-31.54,M,4.0,0166*71  
$GPVTG,96.5,T,,000.73,N,001.35,K*14  
$GPGGA,182120.00,4201.1377,N,09338.1409,W,2,0  
8,0.9,275.89,M,-31.54,M,5.0,0166*79  
$GPVTG,90.4,T,,002.94,N,005.44,K*1A  
  
EXIT
```

Figure 3. PF3000 screen showing NMEA message string.

**Using GPS 1000  
Utility Version 1.0**

The GPS1000 is pre-set at the factory to work with an Ag Leader yield monitor system. Other applications may require special message settings which can be changed with this utility. Refer to the documentation for your software application and/or hardware to determine its required baud rate and NMEA messages.

---

1. Connect the GPS1000 to a computer using either the Ag Leader GPS1000 Mobile Logging or GPS1000 Auxiliary Power/Data cable.
2. Insert the Ag Leader Software Suite CD into the computer CD-ROM drive.
3. The CD Menu will now appear. Click on "Start GPS 1000 Utility Program." The GPS 1000 utility program will now start.
4. Click on the "Connect" button below, then select the COM port and the baud rate for the computer that you are connected to. The correct baud rate should be 4800 unless you have previously changed it on the GPS 1000.
5. The Messages tab will now be displayed. Once you have specified the desired settings, click the "Send Settings" button to send the changes to the GPS1000.

*NOTE: The Messages tab does not display the current configuration of the GPS1000, only the setting options that are available and the recommended factory defaults.*

6. The Serial Data tab will now appear and the selected NMEA messages should now be scrolling down the screen as they are output from the GPS1000. Click pause to stop the message sending for easier viewing.
7. Click on Exit to finish.

**Parts, Tools for Antenna Installation**

The following parts and tools are needed to install the antenna and its bracket:

- 5/16 in. self tapping bolts or 5/16 in. bolts with serrated nuts
- 1/4 in. drill bit for thin metal or 9/32 in. for thicker metal
- Power/Data Cable
- Three white cable tie-downs with self tapping screws
- Three white cable tie-downs
- L-bracket
- Antenna/Receiver
- Marker
- Punch
- ? Hand drill

**Installing the Antenna on Combine or Tractor**

The antenna magnet is very powerful and will stick securely to any metal surface. If needed, an L-bracket for mounting the antenna is provided. The L-bracket is used for mounting the antenna (especially on combines) but not necessary.

Determine a mounting location that is in the center of the swath and the highest point of the vehicle. Ensure that no part of the machine is blocking a clear view of the sky to the antenna. Ensure the antenna is mounted low enough so it won't be knocked off when pulling the vehicle into the shed. Find a mounting location that if it does get struck it can slide off.

Installing with antenna magnet:

Step	Action
1	Locate a flat metal surface on the vehicle; set the antenna on it ensuring the magnet adheres securely.
2	Ensure you leave some slack in the cable between the antenna connection and first tie down. Route cable to cab using cable tie-downs every 12-18 inches to secure cable.

Installing antenna with L-bracket:

Step	Action
1	Place the top surface of the bracket 1/4-in. above the top of the highest metal surface of the vehicle. This ensures the antenna is the highest point of the vehicle and can slide off if struck.

2	After you determine this position, place the L-bracket against the metal surface, mark and punch the places you will be drilling.	
3	Drill the holes in the surface and attach bracket as follows:	
	<b>If the metal is ...</b>	<b>Then use a...</b>
	Thin	1/4-in. drill bit and 5/16 in. bolts with serrated nuts.
	Thick (1/8 in. or more)	9/32 in. bit and self-tapping bolt.
4	Center the antenna on the top surface of the bracket.	
5	Attach the cable to antenna, connecting the end with the plug to antenna.	
6	Attach a white cable tie-down to metal surface 1 or 2 ft below and 6 in. to right of the L-bracket.  <i>NOTE: You may need to increase the above distances, depending on the type of grain tank extension you are using.</i>	
7	Place another white tie-down 3 to 5 ft to the right of the first tie-down.	
8	Use a cable tie and attach the cable to the first white tie-down leaving some slack in cable between antenna connection and tie down to allow for strain relief if the antenna is knocked off the L-bracket.	
9	Use another cable tie to attach the cable to the second tie-down.	
10	Route cable to cab using cable tie-downs to secure cable.	

**Routing the Cable to the Cab**

Follow these steps to route cable into the cab:

Step	Action
1	Find a place on the right side or bottom of the cab to route cable into cab (the point of entry is up to you).  <b>IMPORTANT: The cable can be routed through windows or doors but make sure that there will be no damage to the cable.</b>

Step	Action
2	<p>Attach the GPS cable from the antenna to Port 1 of the PF3000 or Port 1 on the YM 2000. See Figures 4 and 5.</p> <p><i>NOTE: If you are attaching the GPS 1000 to a PF 3000 Pro without GPS, attach the GPS cable to AUX. 1 Port.</i></p> <p><i>NOTE: If you are connecting your GPS 1000 to an alternative logging or mapping device (i.e. handheld or laptop computer), refer to your Operator's Manual for that particular unit for correct cable connection.</i></p>

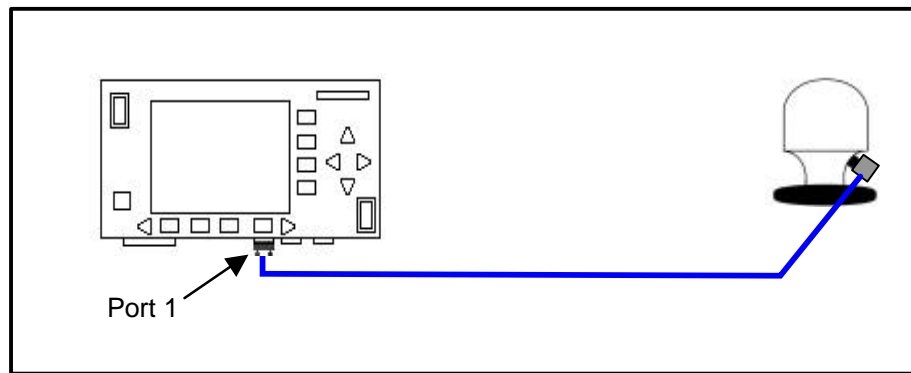

Figure 4. Cable attachment for PF3000 and GPS 1000

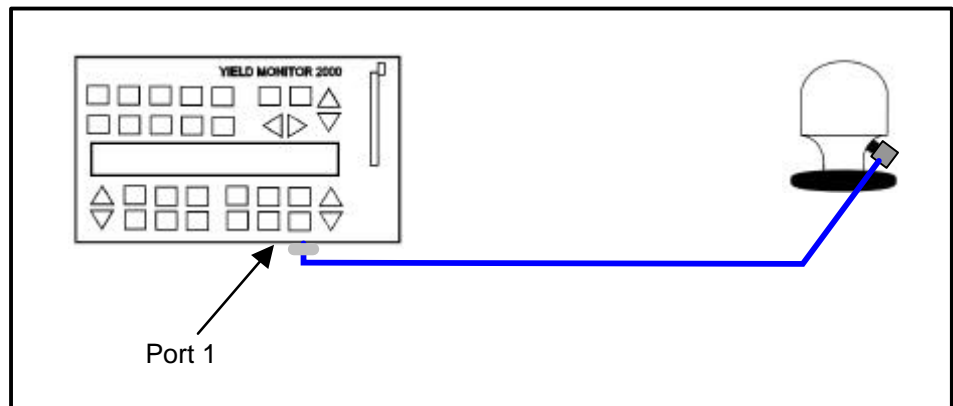

Figure 5. Cable attachment for YM 2000 and GPS 1000

**Other Cable Connections**

Refer to Figures 6 through 8 for some of the possible configurations to attach the GPS 1000.

If you are not using an Ag Leader product refer to that product's Operator's Manual to see how you verify GPS differential.

Step	Action
<b>Cable Attachment</b>	
1	Connect the GPS 1000 cable to the GPS 1000 receiver.
2	Attach Auxiliary Power Data cable to the GPS 1000 cable
3	Connect the GPS Power Supply to the male connector of the pigtail on the Auxiliary Power Cable.
4	Connect the remaining single 9-pin connector from the Auxiliary Power Data Cable to an open COM Port on the PC.

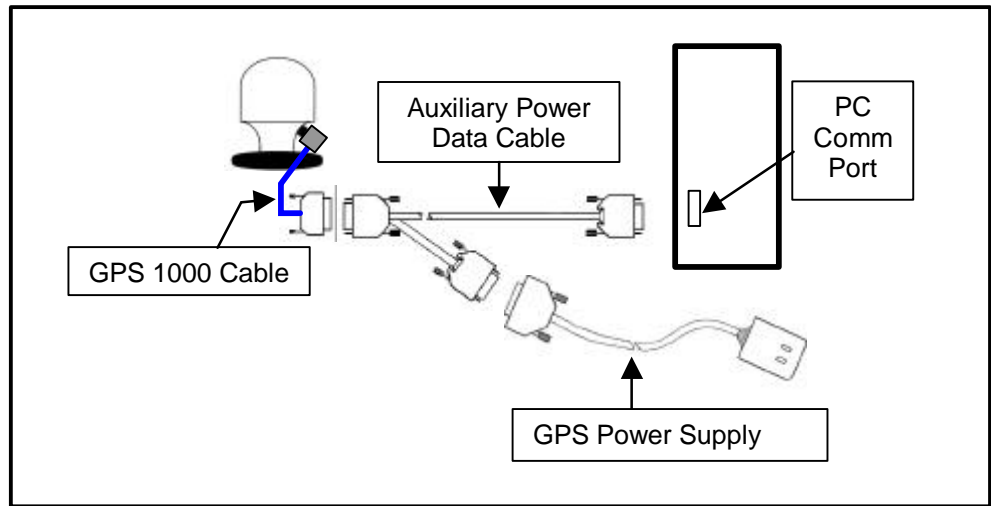

Figure 6. Antenna to PC cable connection

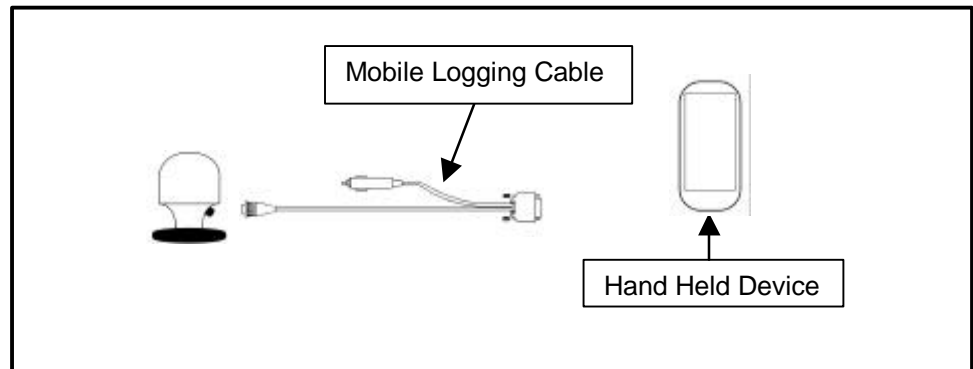

Figure 7. Cable attachment for Handheld GPS device

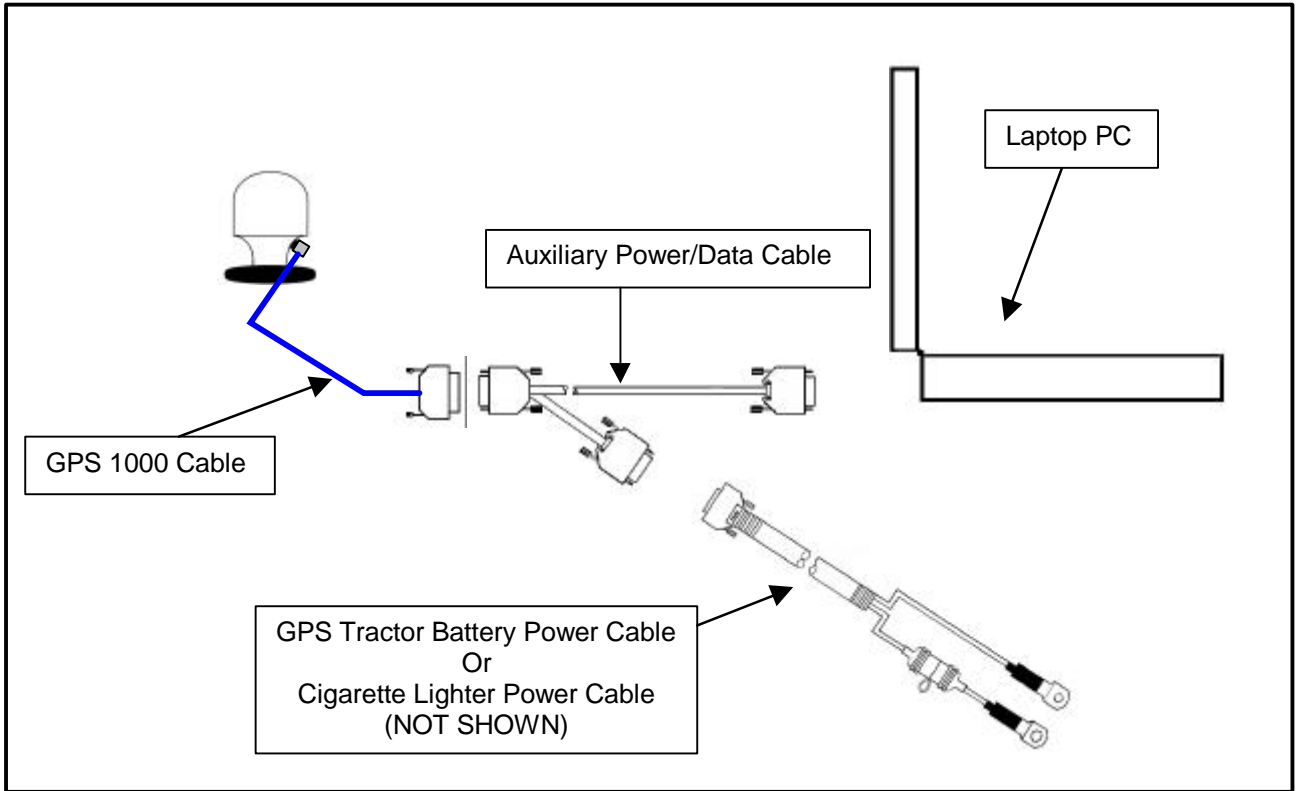

Figure 8. Cable attachment for Laptop PC.

**Environmental Specifications**

Operating Temp: -40C to +85 C  
 Humidity: 100% condensing

**Physical Specifications**

Size: 3.9 in. H x 2.7 in. D  
 Weight (w/o magnet): 10.2 oz (0.64 lbs)  
 (with magnet): 18.8 oz (1.18 lbs)  
 Power: 6 to 16 VDC  
 Power Consumption: Less than 0.2 Amps  
 Connector: 7-pin Conxall

**Receiver Specifications**

GPS Engine: 12 Channel L1 C/A and WAAS  
 Accuracy: WAAS Diff. – 2m RMS  
 GPS only – 4 m RMS  
 Update Rate: 1Hz  
 Cold Start Time: 120 seconds (DGPS)

**Data Input/Output Specification**

- Data is output once per second
- NMEA-0183 output via RS232
- Output rate and parameters can be set from PC
- Default output of GGA and VTG NMEA messages. Other possible output messages are: GLL, GSA, GSV, RMC, ZDA

**Cable Pinouts for YM 2000 and PF3000 Cable**

CONXALL Connector	SIGNAL	COLOR	DB9 Connector
1	TXDA	RED	3
2	RXDA	BLACK	2
3	GND	GREEN	6
4	BOOT	BROWN	CUT
5	RXDB	BLUE	CUT
6	+12V	WHITE	4
7	GND	ORANGE	5

<b>Cable Pinouts for Mobile Cable</b>	<b>CONXALL Connector</b>	<b>SIGNAL</b>	<b>COLOR</b>	<b>DB9 Connector</b>	<b>Cigarette Plug</b>
	<b>1</b>	<b>TXDA</b>	<b>RED</b>	<b>1</b>	
	<b>2</b>	<b>RXDA</b>	<b>BLACK</b>	<b>2</b>	
	<b>3</b>	<b>GND</b>	<b>GREEN</b>	<b>3</b>	
	<b>4</b>			<b>4</b>	
	<b>5</b>			<b>5</b>	
	<b>6</b>	<b>+12V</b>	<b>WHITE</b>	<b>6</b>	<b>WHITE</b>
	<b>7</b>	<b>GND</b>	<b>ORANGE</b>	<b>7</b>	<b>BLACK</b>

**Troubleshooting** The following is a list of problems that you may encounter with the GPS 1000 and suggestions for troubleshooting. If you have a problem with the system, please review the list before calling **Ag Leader Technology**. If your troubleshooting does not solve the problem, please call Technical Support at **Ag Leader Technology** (515-232-5363 ext. 1).

<b>Problem</b>	<b>Cause</b>	<b>Solution</b>
I lose "D" around buildings when using WAAS Differential	<ul style="list-style-type: none"> <li>• WAAS signal isn't being transmitted.</li> <li>• The WAAS satellite you are using is being blocked.</li> </ul>	<ul style="list-style-type: none"> <li>• Go to Raytheon's website (<a href="http://www.raytheon.com/waas/">www.raytheon.com/waas/</a>) and check the current status of WAAS transmission.</li> <li>• There are only two (2) WAAS satellites that are low on the East and West horizon. Building and tree lines can easily block the signal.</li> </ul>
I'm connected to the GPS 1000 but am not getting position data.	<ul style="list-style-type: none"> <li>• Bad Cable or dirty/wet connector pins</li> <li>• The output settings of the GPS have changed.</li> <li>• No Power</li> <li>• The GPS 1000 is damaged.</li> </ul>	<ul style="list-style-type: none"> <li>• Check to make sure the cable isn't damaged and that the connector is clean and dry.</li> <li>• Connect the GPS 1000 to a PC using the Aux. Power/Data cable and run the GPS 1000 utilities program. Set the outputs to what is required for your operation.</li> <li>• Verify that you are properly connected to a power source.</li> <li>• Call Ag Leader Technical Support.</li> </ul>

<b>Parts Name/Description</b>	<b>Part Number</b>	<b>Quantity</b>
<b>YM2000/PF3000 System</b>	<b>3000420</b>	<b>1</b>
Antenna Bracket – L shaped	2000161	1
Antenna Installation Kit (GPS 1000, GPS 4100)	2001310-2	1
CD-ROM – Ag Leader Software Suite	2001601	1
SMS Basic CD w/Wallet	2001606	1
GPS 1000 – Antenna /Receiver	3000415	1
Cable – YM2000/PF3000 to GPS 1000	3000418	1
Manual Insert – GPS 1000	3000021	1
<b>Mobile Logging System</b>	<b>3000424</b>	<b>1</b>
Antenna Installation Kit (GPS 1000, GPS 4100)	2001310-2	1
CD-ROM – Ag Leader Software Suite	2001601	1
SMS Basic CD w/Wallet	2001606	1
GPS 1000 – Antenna /Receiver	3000415	1
Cable – Cigarette Power/Data (GPS 1000)	3000415	1
Manual Insert – GPS 1000	3000021	1
<b>OPTIONAL CABLES</b>		
<b>Auxiliary Power/Data Cable</b>	<b>3000425</b>	
<b>GPS Power Supply Cable</b>	<b>2000825</b>	
<b>GPS Tractor Battery Power Cable</b>	<b>2000827-12</b>	
<b>GPS Cigarette Light Power Cable</b>	<b>2000824</b>	

# GPS 1000 Owners Registration

You will NOT receive upgrade/update information for this product if you are not registered.

Return this sheet in the enclosed postage-paid envelope or by fax.

(Outside the USA 011) -1- 515-232-3595 - fax

*Ag Leader Technology*  
**2202 South Riverside Drive**  
**P.O. Box 2348**  
**Ames, Iowa 50010**

Name: \_\_\_\_\_

Street Address: \_\_\_\_\_

City, State, Country: \_\_\_\_\_

Postal or USA ZIP code: \_\_\_\_\_

Phone # (including Country code or USA area code): \_\_\_\_\_

Mobile Phone #: \_\_\_\_\_ Fax #: \_\_\_\_\_

Email address: \_\_\_\_\_

Ag Leader Dealer: \_\_\_\_\_

Dealer Address: \_\_\_\_\_

Intended Use (Please circle all that apply): Combine Sprayer Planter ATV  
Other, please specify \_\_\_\_\_

PF3000 Serial #: \_\_\_\_\_

PF3000 Pro Serial #: \_\_\_\_\_

GPS 1000 Serial #: \_\_\_\_\_



Summary of Changes for 3000021

March 23, 2001

Initial Release of this Manual Insert.