

Hooking Up
PF3000 or PF3000
Pro

NOTE: Insert these instructions in the Options Section of the PF3000 or PF3000 Pro Operator's Manual.

Parts required for this procedure:

- PF3000 Tall U-bracket (PN 2000105-1)
- PF3000 Pro U-bracket (PN 3001124)
- Battery Cable for PF3000 or PF3000 Pro
PN 2000497-1 (8 ft) or 2000497-2 (16ft)
- HarvestMaster Serial Cable (comes with HarvestMaster yield monitor)

Step-by-Step
Procedure

1. Attach the monitor bracket to the monitor
2. Determine a mounting location for the monitor and mark the holes for the bracket at the location you determined in Step 1. Remove the monitor from the bracket.
3. Drill the holes for the mounting bracket and mount the bracket.
4. Attach the HarvestMaster serial cable to Port 3 of the monitor and run the cable to the HarvestMaster unit and attach to the Host port. See Figure 1.

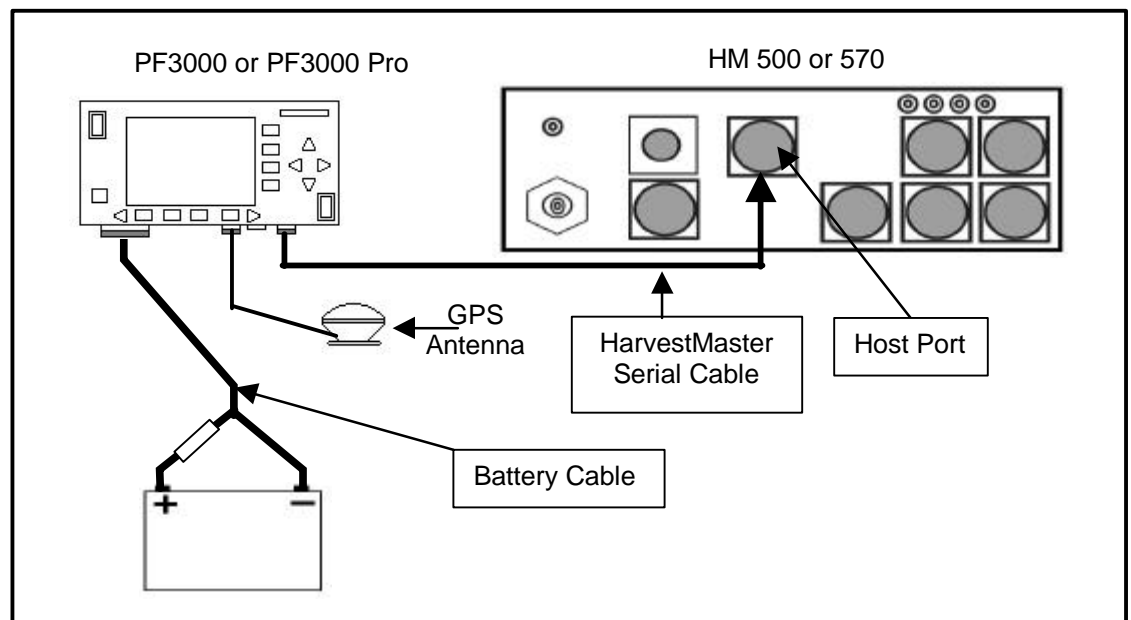
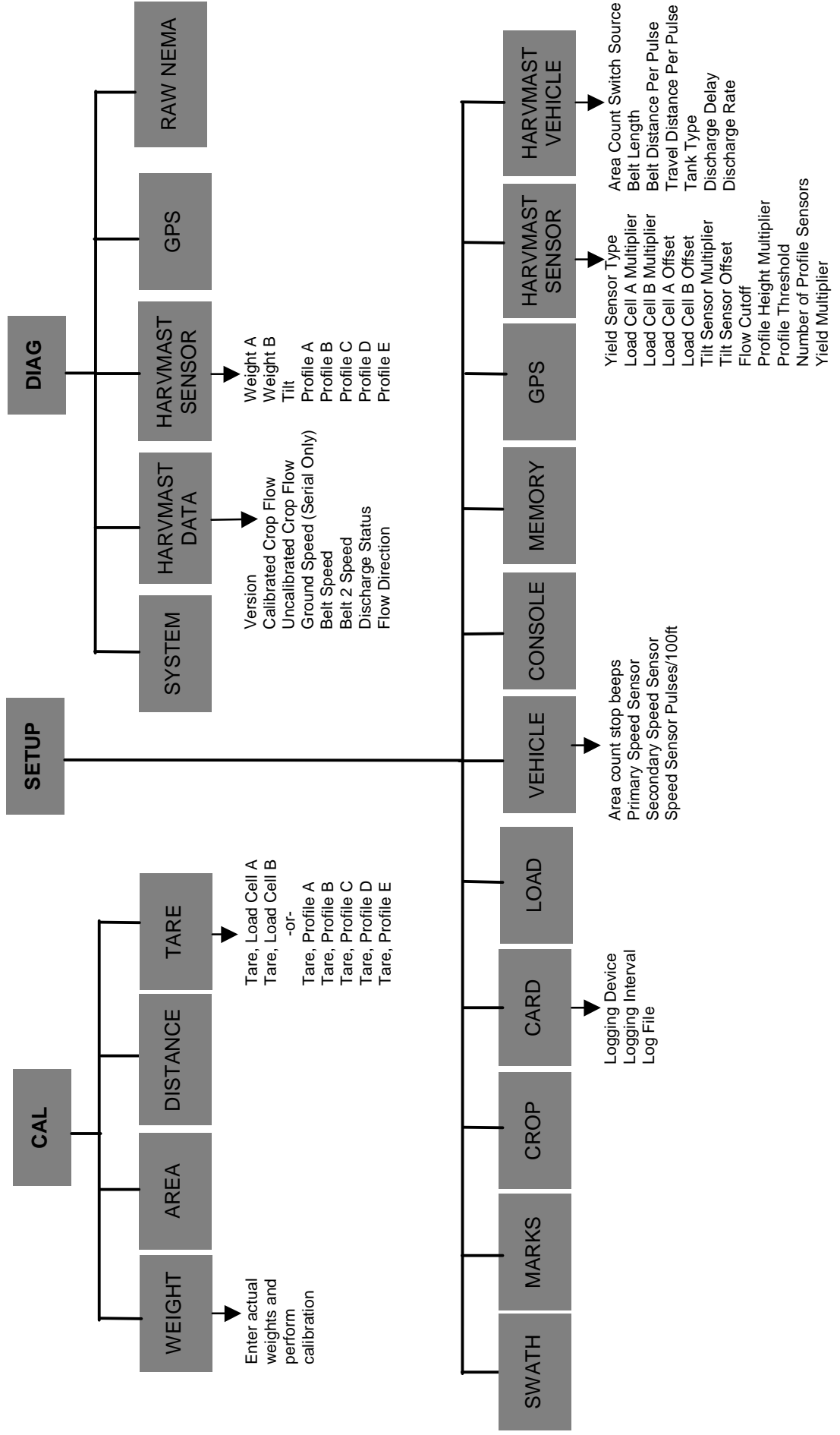
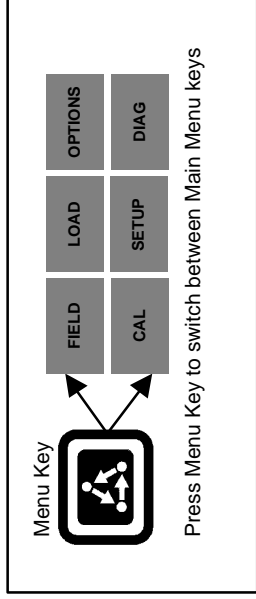

Figure 1. Cable attachment on HarvestMaster Unit

5. Attach the Battery power cable at the battery. The red wire connects to the positive batter terminal. The black wire connects to the negative battery terminal. Route the cable to the monitor, securing the cable away from moving parts every 12 to 18 inches.
6. Attach the battery cable to the 25-pin port on the monitor.
7. Power up the monitor to ensure the monitor is working. If not recheck the cable connections at the battery.

PF3000 or PF3000 Pro – Menu Tree for Harvest Master – September 2000



Before Setup

These instructions only cover information about interfacing with the HarvestMaster HM500 or HM570 yield monitor. Information not found in these instructions regarding the use of the PF3000 or PF3000 Pro can be found in the Operators Manual.

Ensure your PF3000 or PF3000 Pro has the HarvestMaster firmware version installed. Verify by checking the screen after turning on the monitor. It will display "HarvestMaster Version X.XX"

NOTE: You may download the latest firmware version from our web site at www.agleader.com.

NOTE: If you install the HarvestMaster firmware version over a non-HarvestMaster firmware version and you want to save the data from the previous version, copy the data to the card before installing. After installing the HarvestMaster version you will have to Newbox to get the monitor to start. To Newbox, turn on the PF and when "Checking" appears, press and hold down the bottom right arrow key. Press the NEWBOX key when the monitor displays it.

To edit a setting in a setup screen, use the UP or DOWN ARROW keys to highlight the item. Press the EDIT key and use the UP or DOWN or LEFT or RIGHT ARROW keys to change the setting. Press ACCEPT key to make the changed setting final.

Setup – Step 1
Metric or Imperial
Units

To view this screen, press the SETUP key and CONSOLE key.

Set **Units of Measure** to "Imperial" or "Metric". This setting puts the PF in the correct units' mode.

Setup – Step 2
HarvMast Sensor
Setup Screen

To view this screen press the SETUP key and HARVMAST SENSOR key.

The following shows which settings are changeable based on "Yield Sensor Type".

Yield Sensor Type = Load Cell

Load Cell A Multiplier
Load Cell B Multiplier
Load Cell A Offset
Load Cell B Offset
Tilt Sensor Multiplier
Tilt Sensor Offset
Flow Cutoff
Yield Multiplier

Yield Sensor Type = Profile

Flow Cutoff
Profile Height Multiplier
Profile Threshold
Number of Profile Sensors
Yield Multiplier

Yield Sensor Type: Set to the type of sensor used by your HarvestMaster yield monitor. The selections are Load Cell or Profile. The Profile sensor is only used for grapes.

Load Cell A & B Multiplier:

Load Cell Type	Setting if Imperial	Setting if Metric
500 lbs.	50.0 lbs/mV	22.7 kgs/mV
150 lbs.	15.0 lbs/mV	6.81 kgs/mV

To determine which type of load cell you have, look at the "Capacity" value on the sticker on the load cell.

Load Cell A & B Offset: If you do not have a tilt sensor set this to 0. If you have a tilt sensor do the following.

- a. Place the conveyor in a vertical position with the load cells pointing down and the weight of the chain off the idler wheel of load cell.
- b. Go to the HarvestMaster Sensor Diagnostic screen. (Press the EXIT key and the MENU key. Press the DIAG key and HARVMAST SENSOR key.)
- c. Write down the "gross" weight for Weight A and Weight B. Go back to the Harvmast Sensor Setup Screen and enter gross Weight A for Load Cell A Offset and gross Weight B for Load Cell B Offset.

Tilt Sensor Multiplier: This is the degrees of tilt per volt. If you do not have a tilt sensor set this to 0. If you do have a tilt sensor, obtain this setting from the label on the tilt sensor. To check if the value is correct do the following:

- a. Place the portion of the conveyor with the load cells level. Use an angle finder to make sure it is perfectly level.
- b. Go to the HarvestMaster Sensor Diagnostic screen and view "Tilt".
- c. Adjust the position of the tilt sensor until the "Tilt" reading is set to 0.
- d. Using the angle finder, change the conveyor to a known angle (such as 30 degrees).
- e. Check the "Tilt" reading under the HarvestMaster Sensor Diagnostic screen. If it does not match the known angle, divide the known angle by the sensor reading. Multiply the result by the current Tilt Sensor Multiplier. This is the final setting. Enter this value at the HarvestMaster Sensor Setup Screen.

Example:

Known Angle: 30 degrees

Tilt sensor reading: 33 degrees

Current Tilt Sensor Multiplier: 67 degrees

$$\frac{30}{33} = 0.909$$

$$0.909 \times 67 = 61$$

Final Tilt Sensor Multiplier Setting is 61.

Tilt Sensor Offset: This should be set to 0 if you do not have a tilt sensor. If using a tilt sensor, and it cannot be adjusted to read “0” when the conveyor is horizontal, set Tilt Sensor Offset according to the following:

- a. With tilt sensor adjusted to its final adjustment and with conveyor perfectly level, view "Tilt" reading under the HarvestMaster Sensor Diagnostic Screen.
- b. Enter the "Tilt" reading as the setting for "Tilt Sensor Offset", but enter the opposite sign of the “Tilt” value. Example: If “Tilt” value is 2, enter -2 for “Tilt Sensor Offset”. If “Tilt” value is -2, enter 2 for “Tilt Sensor Offset”.

Flow Cutoff: This is the minimum flow rate for recording data. Initially, this is usually set to zero.

Profile Height Multiplier: Set to - 3.34 inches. If using metric units set to - 8.48 cm.

Profile Threshold: Set to 0 inches. If using metric units set to 0 cm.

Number of Profile Sensors: Set to 5.

Yield Multiplier: If you have been using the HarvestMaster Mobile Field Computer and are satisfied with the accuracy do not change this setting. If you have not used the Mobile Field Computer or are not satisfied with your accuracy set to:

- 1.00 if using Load Cell sensors
- 3.00 if using Profile sensors (only used for Grapes)

If you change this setting you will have to calibrate for weight. See “Weight Calibration Screen” instructions in the Calibration Section of this instruction set.

IMPORTANT: After you set the Yield Multiplier value, DO NOT CHANGE it. Changing this value after setup will adversely impact harvest accuracy.

Setup – Step 3
HarvMast Vehicle
Setup Screen

To view this screen press the SETUP key and HARVMAS T VEHICLE key.

Area Count Switch Source: Selections are Belt Speed or Hold/Run. Set this to "Belt Speed" for area counting to be based on when the Belt is stopped or moving. (Stopped = Area Off, Moving = Area On). Set this to "Hold/Run" for area counting to be based on the Hold/Run switch. (Hold = Area Off, Run = Area On).

Note: The Ag Leader Area Count switch (located on bottom right of front panel) must be on in order to count area.

Belt Length: Measure the conveyor belt length, enter this length for this setting. If using Imperial units enter feet, if using Metric units enter meters.

Belt Distance Per Pulse: This is the pulses per foot (or meters) of belt travel detected by the speed sensor. The sensor is located on the drive shaft.

Belt Distance Per Pulse = Sprocket Diameter (feet or meters) x 3.14.

Note: This formula assumes that the sensor outputs one pulses per revolution of sprocket. Pulse is generated by magnet passing the speed sensor.

Measure sprocket diameter from low points where chain rests not from the tips or ends of the sprocket cogs.

Travel Distance Per Pulse: Measure the diameter of the wheel that has the ground speed sensor installed. Use the following formula to determine the setting:

$$\text{Travel Distance Per Pulse} = \frac{\text{Tire Diameter (feet or meters)} \times 3.14}{\text{Number of magnets}}$$

Tank Type: If you are not using a sugar beet harvester ignore this setting. If you are using a sugar beet harvester, refer to the HarvestMaster instructions for the proper setting.

Discharge Delay: If you are not using a sugar beet harvester ignore this setting. If you are using a sugar beet harvester, this setting is the time in seconds from when the beets come out of the tank until they pass the weighing rollers again, on their way to the truck. Typically this setting is 8 – 11 seconds.

Discharge Rate: If you are not using a sugar beet harvester ignore this setting. If you are using a sugar beet harvester, this is the rate in lbs/sec (or kgs/sec if metric) at which the beets come out of the holding tank.

Determine this setting by timing how much material comes out. Typical settings are 50 – 100 lbs/sec (23 – 45 kgs/sec).

Setup – Step 4
Swath Setup Screen

To view this screen press the SETUP key and SWATH key.

- a) Select the crop you will harvest.
 - b) Press the EDIT # ROWS key and set the correct rows.
 - c) Press the EDIT SPACING key and set the correct spacing.
-

Setup – Step 5
Vehicle Setup Screen

To view this screen press the SETUP key and VEHICLE key.

It is recommended to set the **Primary Speed Sensor** to “Serial”. The only other valid option is “GPS”. Do not set the Primary Speed Sensor to “Wheel”, “Radar” or “Track”.

The default secondary speed sensor is “Wheel”. It is recommended to leave it set on “Wheel”. The PF will not actually be connected to a secondary speed signal but has to use the calibration number of the secondary speed sensor for the primary speed sensor.

Setup – Step 6
Card Setup Screen

To view this screen press the SETUP key and CARD key.

Log Device: If you are using a GPS receiver, set to “Memory Card”

Logging Interval: Set to 2 or 3 seconds. 1 second is not recommended because it logs more data than needed for most users.

Log File: After pressing EDIT key, press CREATE FILE key to create a new log file.

Note: The monitor will automatically prompt you to make a new log file everyday.

Setup – Step 7
Create Field and
Loads and set Crop
Type

Fields and Loads can be setup ahead of harvest or during harvest. Refer to the steps below:

- a) Press MENU key until FIELD key and LOAD key is displayed on bottom. Press FIELD key (press twice if load displayed on top line) to display field on entire screen.
 - b) If desired, name the field by pressing the Right Arrow key. Use the Up or Down Arrow keys to set the character. Set another character by moving the cursor using the Left or Right Arrow key. Press ACCEPT key once when finished.
 - c) Press key to right of line displaying crop. Use Up or Down Arrow keys and set the crop. Press ACCEPT key twice.
 - d) To create or change to a different field, press the FIELD key again. Use Up or Down Arrow keys to select a different field. Name field and set crop. Press ACCEPT key until at main screen. Field is now active.
 - e) To create or change to a different load, press the LOAD key. Change or name the load as described for field in steps b & d. You can not set the crop on a load.
-

Calibration – Step 1
Tare Calibration
Screen

To view this screen, press the CAL key and TARE key.

Press the PERFORM TARE key to start the tare. Make sure the conveyor is running empty when you press PERFORM TARE.

The tare value gets averaged over the belt length, thus the tare will take several seconds (one complete belt revolution) to complete. The tare is complete when “Tare Complete” gets to 100%.

In many operations, you might initiate a tare operation only once per day, or even once every few days. In muddy operations, it is advisable to tare the system right after completing a load.

Calibration – Step 2
Weight Calibration
Screen

To view this screen, press the CAL key and WEIGHT key. Refer to the steps below:

Note: It is recommended to obtain the actual weight of three or four loads for each crop harvested. Also, it is recommended that you tare the conveyor before harvesting each load being used for calibration.

- a) Use the Up or Down Arrow keys to select the crop.
- b) Press ENTER WEIGHT key to add actual weights.
 - 1) Use the Up or Down Arrow keys to set field.
 - 2) Press key to right of Load and use Up or Down Arrow keys to set load.
 - 3) Press key to right of “Act. Weight” and use Up or Down Arrow keys to set actual weight.
 - 4) Repeat steps 1-3 and enter all actual weights. Press EXIT key when finished.
- c) Press SHOW CAL LOADS key.
- d) Press PERFORM CAL key. View the maximum and average error and press the EXIT key.
- e) If errors of any loads are too high you can uncheck the load by pressing the CAL ON/OFF key. Press PERFORM CAL key again if you uncheck any loads.

Note: When you calibrate weight for a crop, all the data that was previously recorded and will be recorded (including logged data) for the crop will be adjusted to the same calibration.

**Operation
Information**

Active Field and Load: This is the field and load that information will be recorded in. These are displayed on the top line (if load not displayed, press LOAD key once).

To change the active field and load press the FIELD or LOAD key and use the Up or Down Arrow keys to scroll to new field or load. Press ACCEPT key to set it as active. Refer to the "Setup-Step 7" instructions for more information.

Display Items: To change any of the four display items, press the key to the right of a display item. After that, press the bottom right or left arrow keys to see all the display items. Suggested items to display are: "Yield", "Crop Flow", "Ground Speed", and "Weight". Other useful display items are "Belt Speed", "Swath" or "Area"

Showing fields and loads totals: To show the field totals for each display item, display the field only on the top line (press the FIELD key once if field and load on top line). To show the load totals for each display item, display the field and load on the top line (press the LOAD key once if field only is on top line).

Copying data to card: When using a memory card, the monitor will prompt to copy to the card every time the monitor is shut off. Be sure to do this. You can manually copy data to the card under the Card Setup screen (press the SETUP key and CARD key). Press the COPY TO CARD key to copy data to the file set as the "Log File".

Logging to card criteria: Anytime crop flow is greater than zero or area counting is on, the PF will log data to the card. An arrow appears pointing towards the card to indicate that data is being logged.

* * *